

# INSTALLATION AND CARE GUIDE

---

## WOODBIDGE® WASHLET TOILET BW5100S

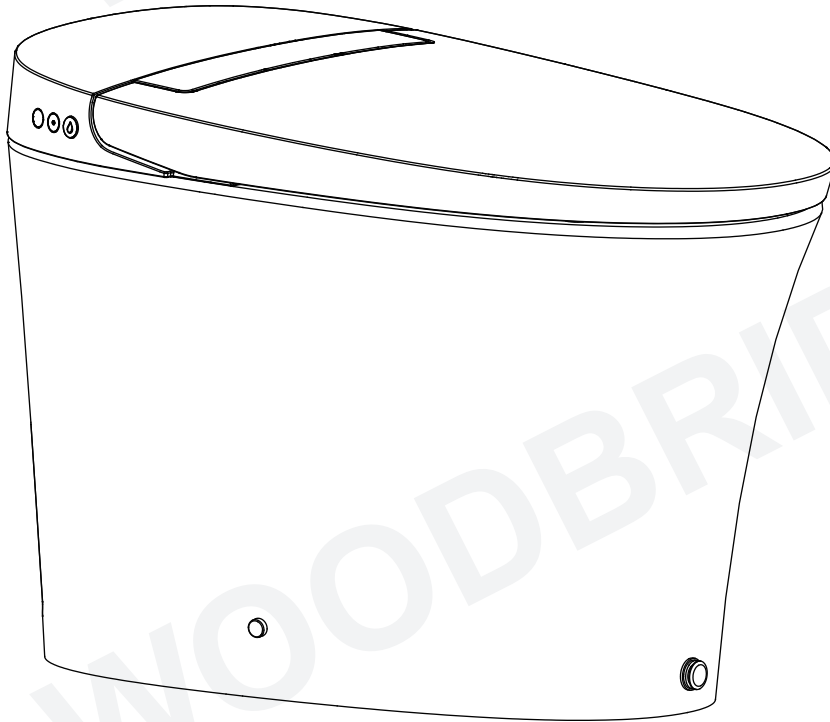

Compliance with the following codes & standard:

- 2015 Uniform Plumbing Code® (UPC)
- 2018 International Plumbing Code® (IPC)
- 2018 International Residential Code® (IRC)
- CSA B45.5 / IAPMO Z124-2017- Plastic Plumbing Fixtures

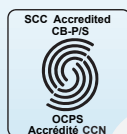

Customer Service Phone: 562-229-0088. (Monday - Friday 9 AM - 5 PM Pacific Time)  
Or Email: [help@woodbridgebath.com](mailto:help@woodbridgebath.com)

### Installation

<b>Safety instructions</b>	1
<b>List of materials</b>	4
<b>Technical drawings</b>	5
<b>Parts identification</b>	6
<b>Installation of ceramic toilet</b>	7
<b>Previous preparation</b>	9
<b>Installation of sensor module</b> (Only apply to models with wave-to-flush function)	10

### Maintenance

<b>Daily maintenance</b>	13
1.Main unit care and maintenance	
2.Maintenance of filter net	
<b>Emergency troubleshooting</b>	14
1.Electricity and water supply cut-off	
2.Replacement of battery	
3.Low voltage battery determination and replacement (Only apply to models with wave-to-flush function)	
4.When the product is left unused for long time	



### Others

<b>Technical specification</b>	16
<b>The illustration of Main Unit Keys</b>	16
<b>Warranty Card</b>	17



Please read the instructions carefully before installation and keep it available for future maintenance or reference.





Failure to observe this instruction can cause body injury and property damage.

### Symbol Illustration

 Warning	Indicates that failure to follow the instruction may cause serious injury or a fatal.
 Caution	Indicates that failure to follow the instruction may cause body injury or property damage.

### Symbol Illustration

Symbol	Indication
	Prohibited activities
	Mandatory activities

 Warning	
	Do not throw cigarettes and other burning stuff into toilet, otherwise it might cause malfunction.
	<p>Do NOT disassemble, repair or modify this product by yourself, otherwise it may cause fire or malfunction.</p> <p>Do NOT pour water or detergent on the main unit or battery box plug, otherwise it may cause fire or electric shock.</p> <p>Do NOT handle the battery box plug with wet hands, otherwise it may cause malfunction.</p> <p>This product is factory equipped with a specific battery device. Do NOT use any battery device other than the factory equipped battery device, otherwise it may cause fire or malfunction.</p> <p>If the electric cord of battery box is damaged, it must be replaced by the manufacturer, its service center or equivalent specialist to avoid malfunction.</p> <p>This product is electric appliance, so it must be placed far away from water. Please don't drench urine and other liquid to it.</p> <p>Do not position the product on its side or upside down while making electrical connections with the battery box, otherwise it may cause fire or burning.</p>
 Mandatory activities	Do not install or use the product in wet places as steam room etc.

 Warning

  
Mandatory  
activities

Only use the factory equipped battery box and 1.5V “AA” alkaline battery.  
When move the product from cold or wet environment into normal room temperature, wait for 2 hours until the condensation water is fully volatilized. Doing so can prevent the product from electrical short-circuit.

 Caution



Do not use the product in the places close to bathtub or water tank.  
Do not place the product in water or other liquids.  
Do NOT reach for a product that has fallen into water. Unplug the battery box immediately  
Do not stand on the ceramic toilet. Do not hit the ceramic. A heavy impact on ceramic leads to damage and water leakage.  
Never embed ceramic toilet base in cementitious material ( such as cement mortar). It may lead to expansion crack.  
Do not stand on product unit, seat and cover.  
Do not use lacquer thinner, petrol, liquid medicine, detergent, insecticide, toilet cleanser and scrubbing brush to clean the product.  
Only use tap water or potable water; otherwise it may cause chafing.  
Exposure to direct sunlight is prohibited.  
This product is equipped with soft-closing seal cover. Heavy pressing or pushing may damage the soft-closing damper.  
Do not connect water supply to heater outlet. Make sure inlet water temperature at 3~35 °C,exceeding the specified range will result in the built-in heating module not working.  
Do not lean against the seat cover when using the product, to avoid damage.  
Do not try flushing the newsprint,diapers, sanitary napkins and other items easy to chock the toilet.  
If this product is malfunctioning, stop using immediately, unplug the battery box, turn off water supply, and contact the service provider.

  
Mandatory  
activities

When installing, disassembling, repairing, and maintaining the product, you must unplug the power supply and close the water supply valve.  
Do not use in an environment below 0 °C.  
If this product will not be used for an extended period of time (over 3 days), it is recommended to unplug the battery box, remove batteries, turn off water supply, and drain any water in the product.  
When used by people (including children) who lack physical, sensory, intellectual abilities, or lack of experience and common sense, This product needs to be used under the supervision of a person, and patients with heart disease should use it with caution.  
Do not let children play with this product.  
To prevent damage caused by freezing, please implement warmth measures to increase the temperature of the toilet.

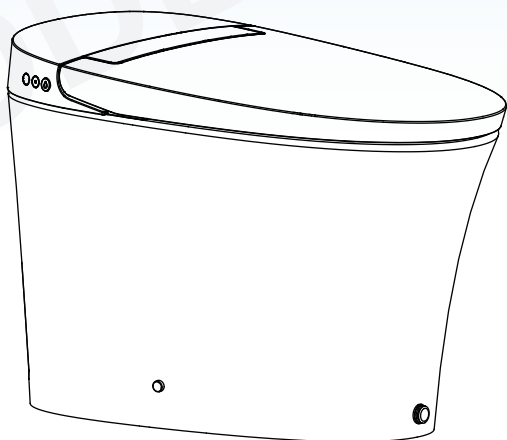

Main Unit

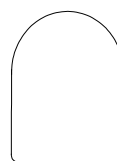

Installation Cardboard

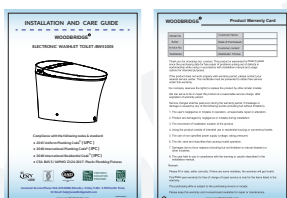

Installation Manual  
Warranty Card

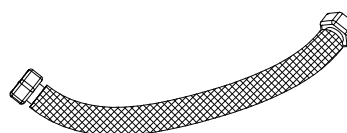

Braided hose

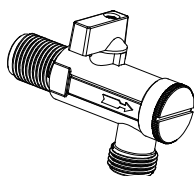

Angle Valve

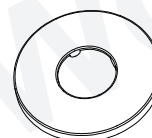

Flange



Sealing Flange



Battery box

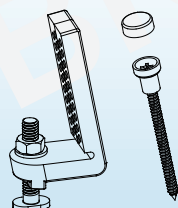

Mounting accessory kit



Sensor module assembly (optional)

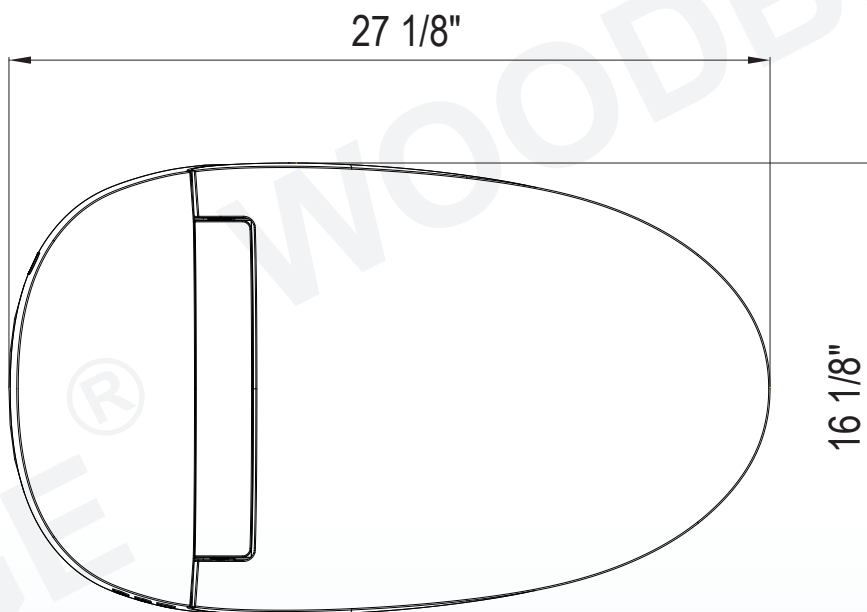
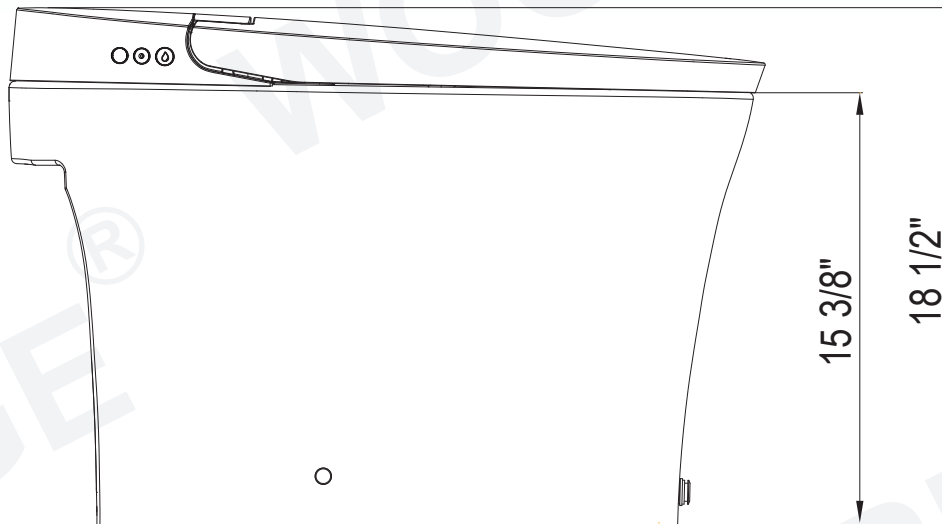

The product drawing is for reference only, and we reserve the right to modify the appearance of the product.

### Left side

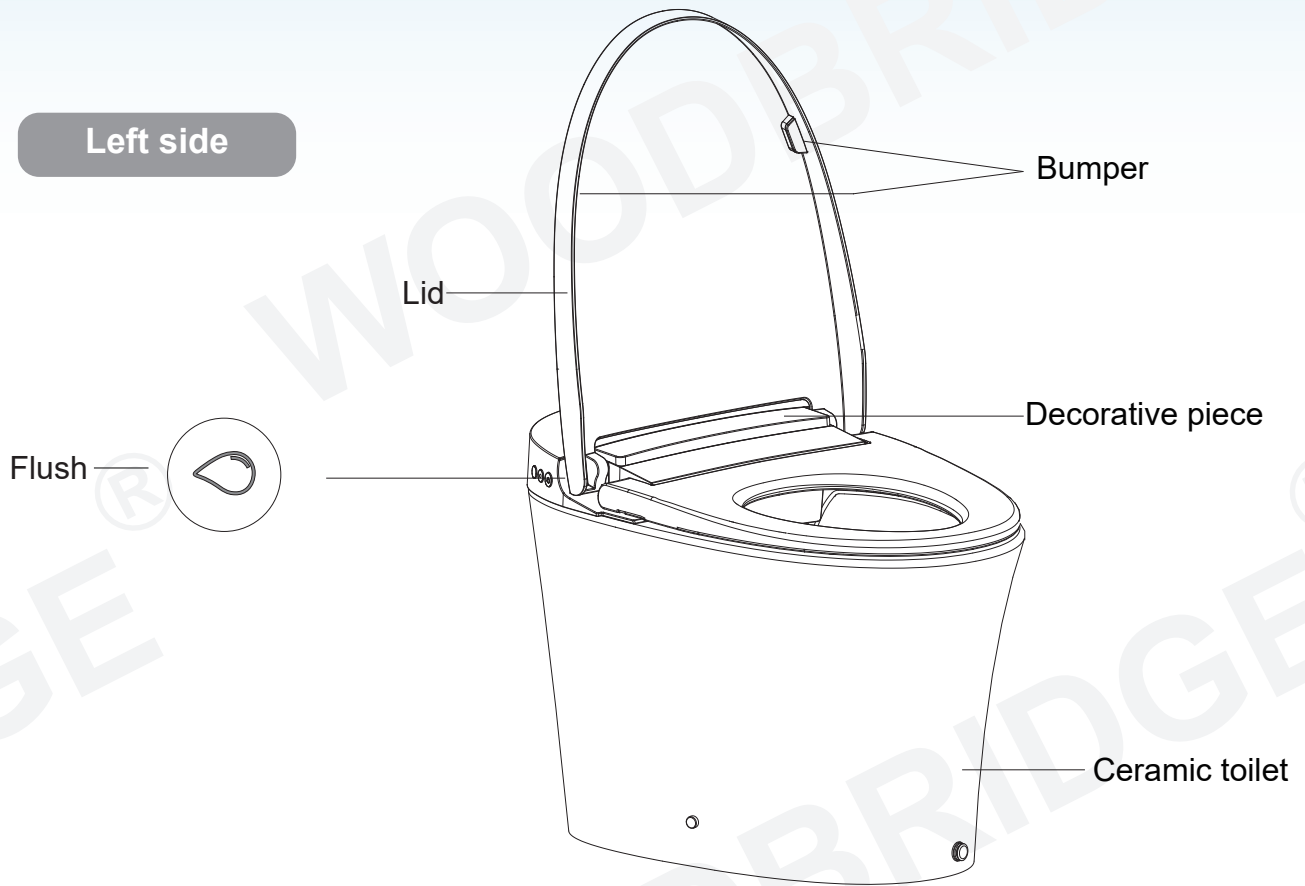

### Right side

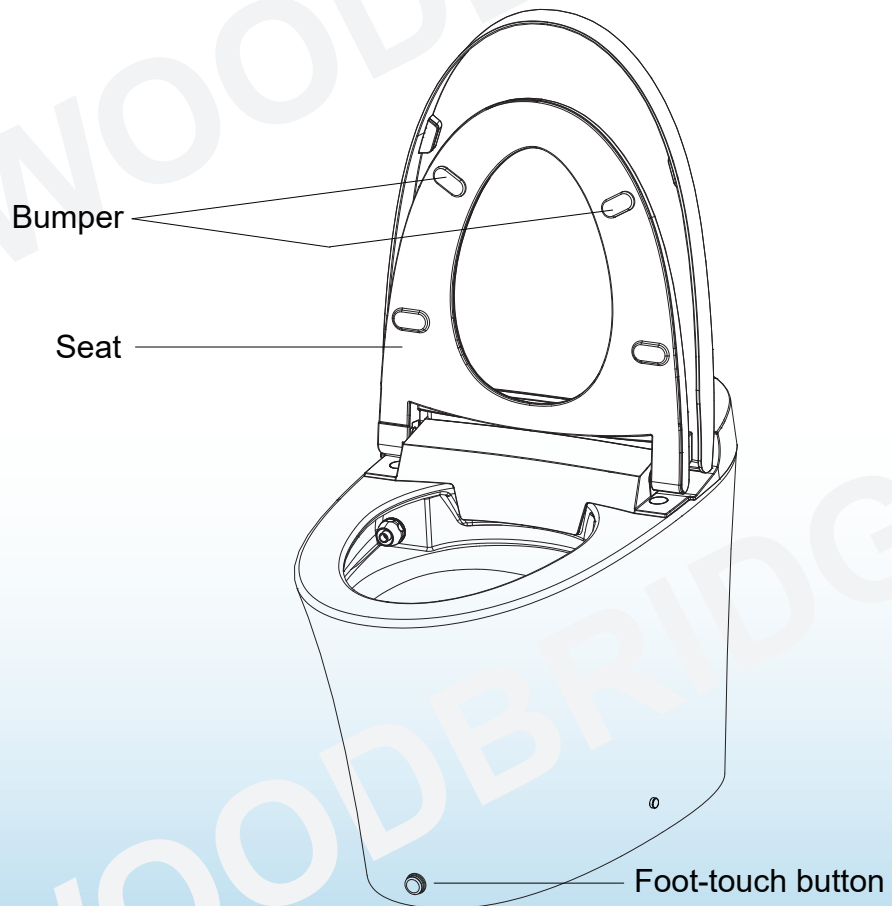

### ⚠️ Precaution before installing

- Minimum dynamic working water pressure: 0.09MPa(13.5PSI) or more (Min15.0L/3.96G or more), failure to meet this pressure will not achieve the best flushing effect.

Remark: Apply the methods below if you don't have water pressure testing device.

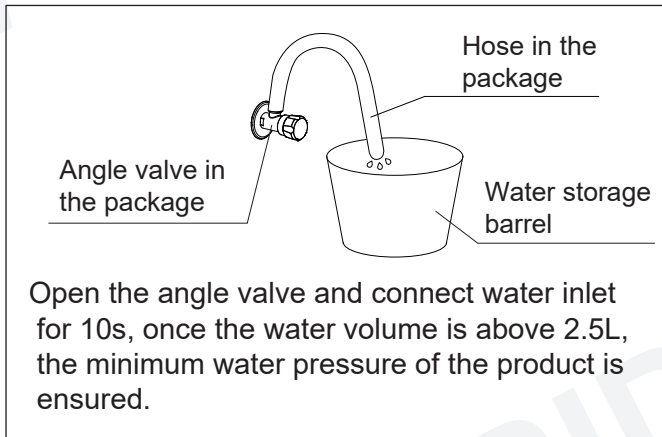

### 1. Installation of mating angle valve

- Draw drain outlet centerline on the floor, Install angle valve at proper position on wall according to dimension of toilet.

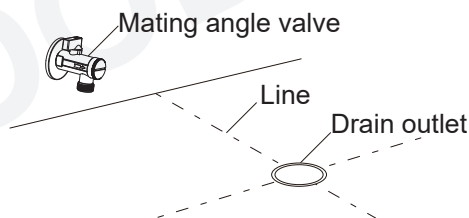

### 2. Cardboard installation

- Align cardboard with the centerline of drain outlet;
- Draw contour line according to cardboard;

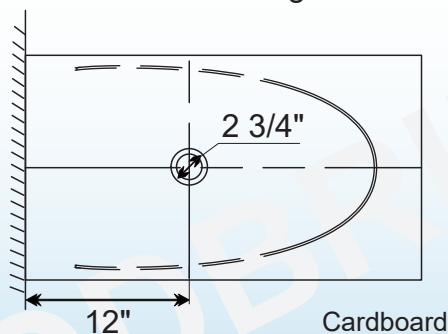

### 3. Hose

- Connect the water inlet and angle valve of the toilet with the matching hose and tighten it

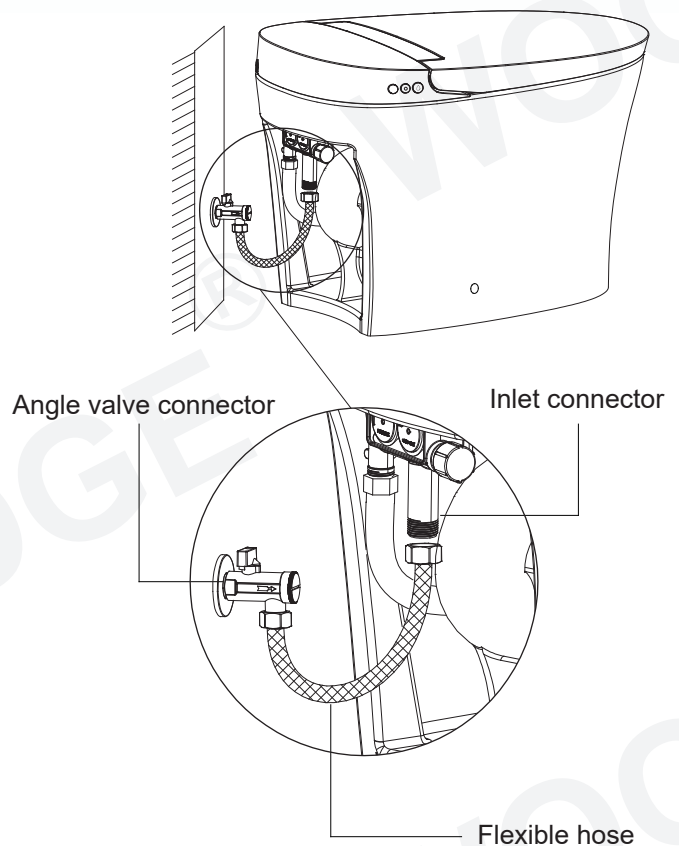

### 4. Mounting bracket installation

- Assemble the mounting bracket with bolts and then install them to the pre-installed flange plate on the ground and lock tight with nuts.

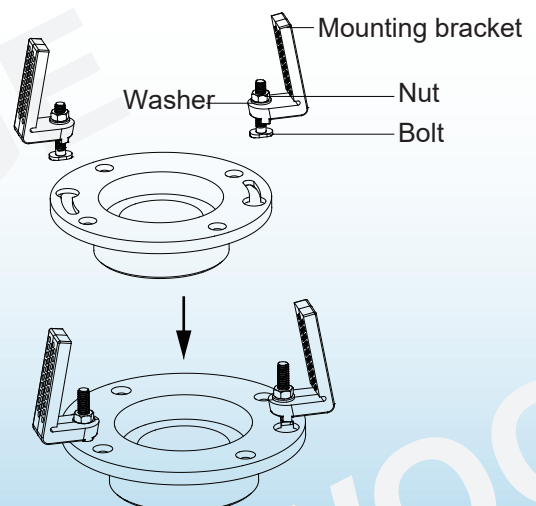



## 5. Ceramic toilet installation

- Install sealing flange into drain outlet;  
Install ceramic toilet on corresponding position according to contour line.

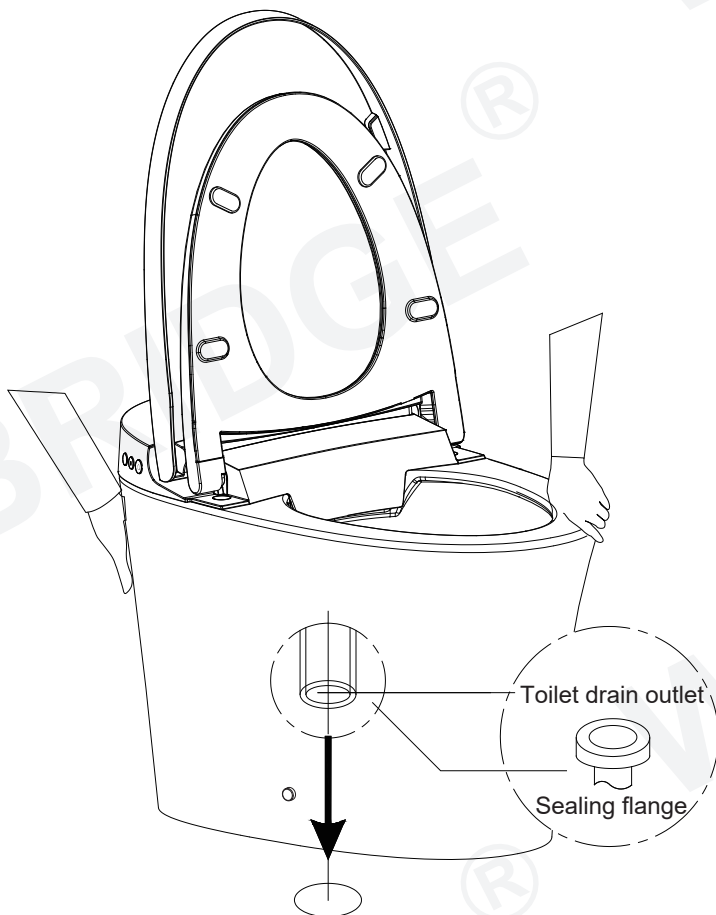

## 6. Screw installation

- Put the screw through the fixing sleeve and then install it through the holes (on both sides of the toilet ceramic) to the mounting bracket on the ground, and lock tight with a tool;
- Put the decorative cap on the fixing sleeve.

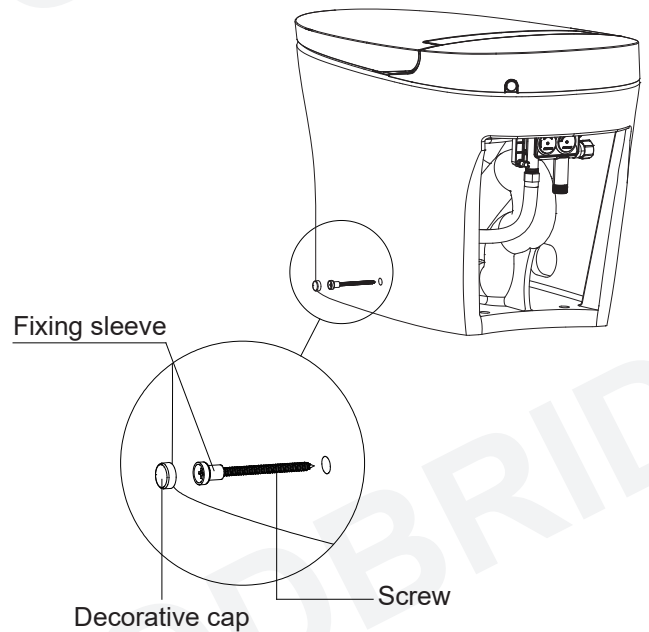

## 7. Silicone Caulking application

- Apply high quality silicone caulking around the lower edge of the toilet.

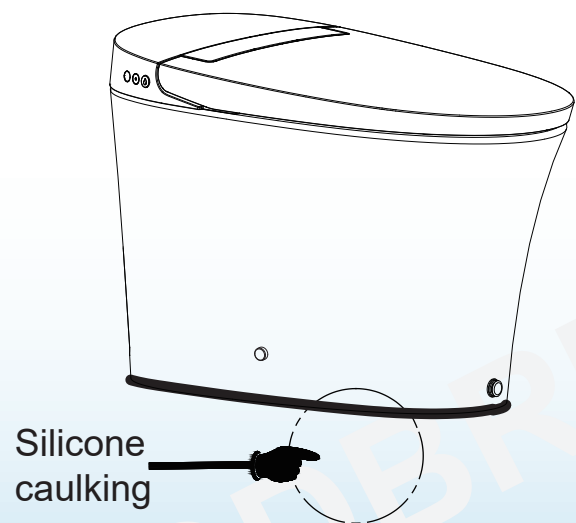

### Tips:

- Please clean the drain outlet;
- Please make sure ceramic toilet outlet sits perfectly on drain outlet.

### 1. Turn on the angle valve

Check thread connection, make sure no leakage is found, unscrew angle valve counter clockwise to maximum opening.  
(Tips: The angle valve handle has a larger torque during the first time turning)

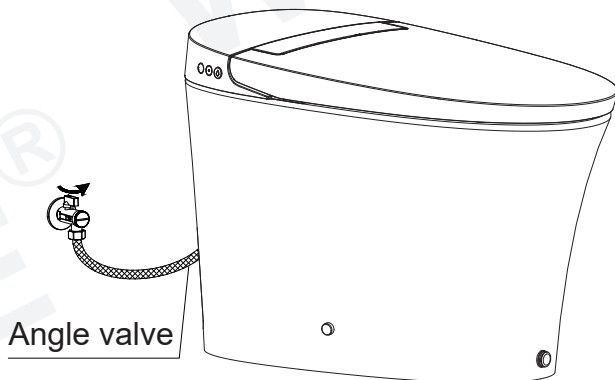

### 2. Power Connection

Take out the battery box from the accessory kit and install 4pcs 1.5V "AA" alkaline batteries. Plug the DC plug of battery box into the DC socket of toilet and then stick the battery box to the Velcro on the bottom of the toilet.

#### Notes:

1. Must be 1.5V "AA" alkaline battery (Battery not included)
2. Different brands, different used and new batteries cannot be mixed.
3. Battery life will be significantly reduced when using non-alkaline batteries;
4. When installing the inner box components, follow the installation direction shown in the label.

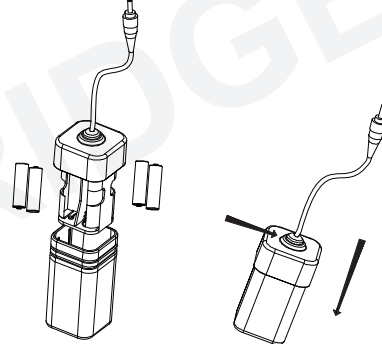

When re-installing the cover of battery box, use your fingers to squeeze the side of rubber plug to exhaust air out of the box and ensure sealing.

### 3. Self-inspection

After the batteries are successfully installed, the red indicator light will flash once.

(Only apply to models with wave-to-flush function)

### 1. Battery installation

- put batteries (3pcs 1.5V "AAA" alkaline batteries) into the sensor module and tighten the screws. (The product doesn't come with batteries)

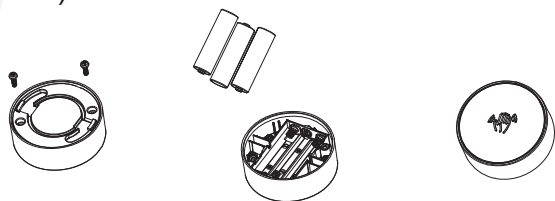

※Note: The batteries should be installed to sensor module within three minutes after batteries are installed to control module, the codes will be automatically matched between the modules.

### 2. Sensor module bracket installation

- The installation method of control module holder can be selected according to the installation wall.

Method A: Screw fixing - Suitable for installation on rough gray walls and other rough walls

Method B: Adhesive fixing - Suitable for installation on tiles and other smooth walls.

#### Method A: Screw fixing

- A-1: Put control module holder on the pre-installation position and mark the positioning hole on the wall with a pen (when deciding the mounting location, ensure the user hand can touch the sensor module while sitting on the toilet)

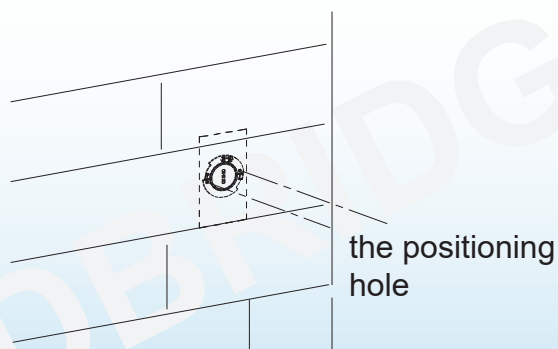

- A-2: Drill two holes with diameter 6mm in the vertical direction of the wall, the center distance between the two holes is about 2", and the depth is 3/16".

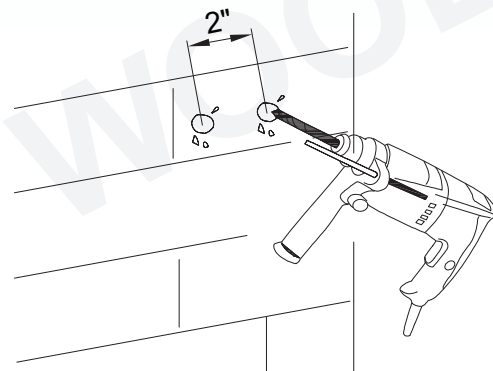

- A-3: Insert the expansion tubes into the holes on the wall, place sensor module bracket against the wall, align the holes of the bracket with the expansion tubes and put screw into expansion tubes to lock it.

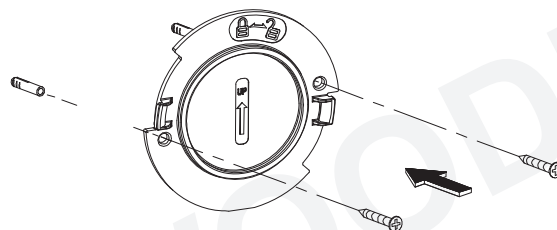

- A-4: Align sensor module slot with sensor module bracket, and then rotate it counterclockwise to lock it.

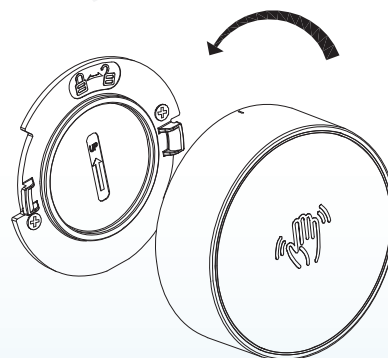

Note: Do not install and use the product in a wet place such as a bathroom, and prohibit it from being exposed to water.

## Method B: Adhesive fixing

B-1: Clean and dry the pre-installation area of sensor module bracket (when deciding the installation position, it should be noted that when a person sits on the seat, ensure that the hand can touch the sensor module).

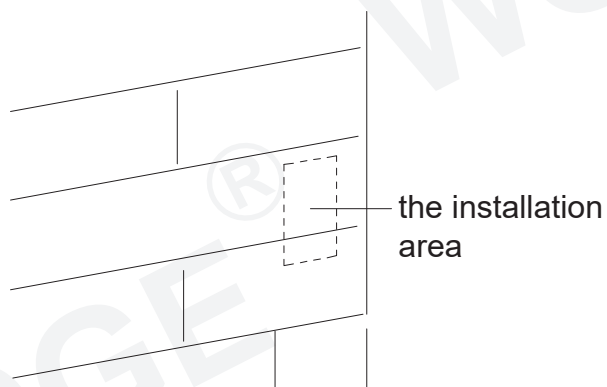

B-2: Tear off the double-sided adhesive sticker on the back of the sensor module bracket and paste it vertically on the wall.

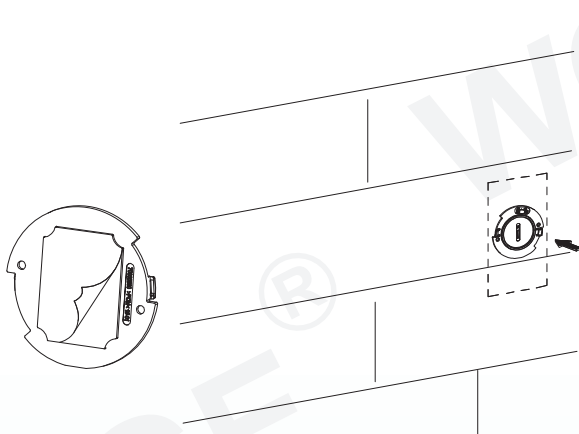

B-3: Align sensor module slot with mounting bracket, and then rotate it counterclockwise to lock it.

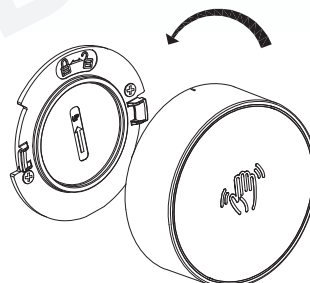

Note: Do not install and use the product in a wet place such as a bathroom, and prohibit it from being exposed to water.

## 3. Modules code matching

- Step I  
Remove batteries from both control module and sensor module, Wait for 1 minute.

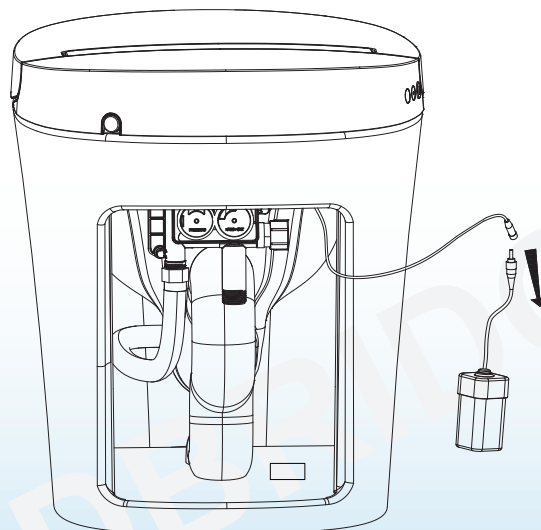
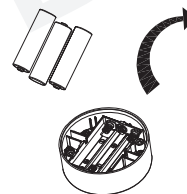

- Step II  
First connect the battery box (with batteries installed) to the main unit.

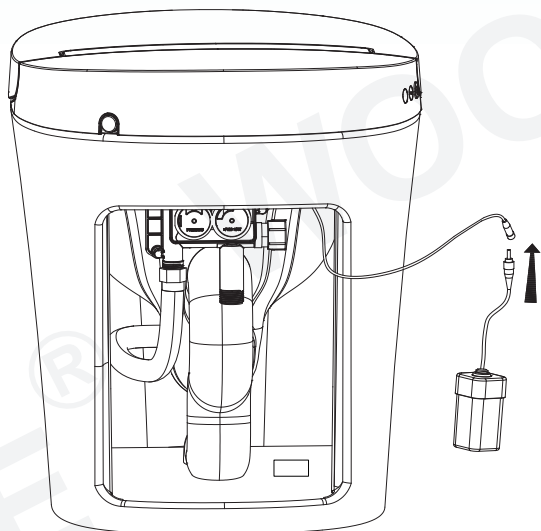

- Step III  
Install sensor module batteries within three minutes after installing control module batteries. After installation, perform sensing once and finish the code matching.

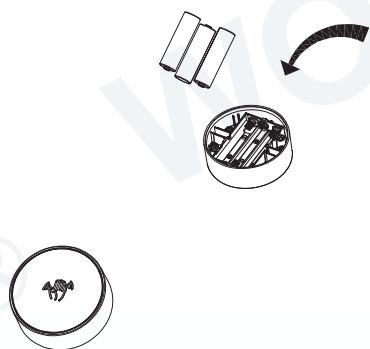

- If the sensor module lights up after installation, but the product cannot be sensed to flush, please reset batteries and match codes.

## 4. Sensor flushing

- Wave hand in front of the sensor module to activate sensor flushing.



### Main unit care and maintenance

Use only a soft, damp cloth to clean.  
Avoid using harsh chemicals.

Note: If the toilet is with off-seat auto flushing function, it may activate auto flushing during the cleaning.

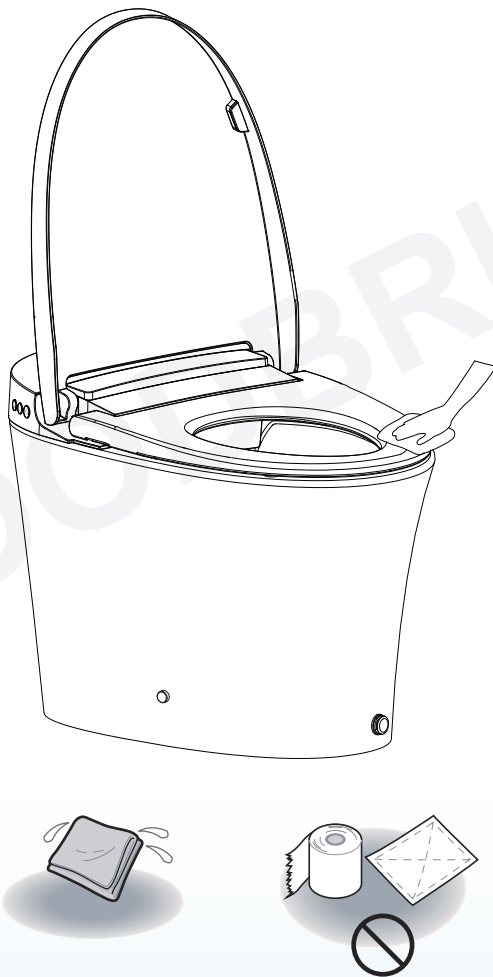

### Maintenance of filter net

Time for maintenance: It is under normal water pressure but poor flush performance occurs.

1. Turn off power and the angle valve
2. Unscrew angle valve nut

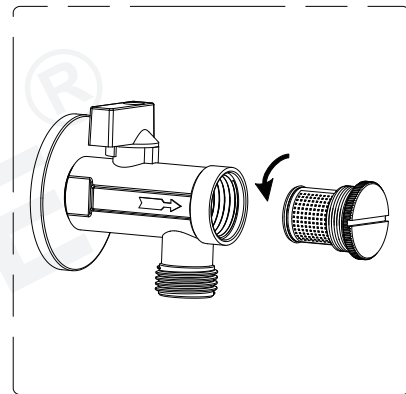

3. Remove filter net

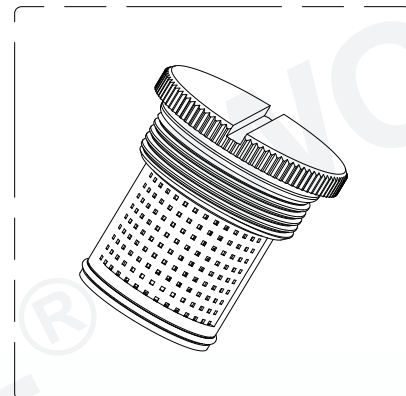

4. Use the brush to clean filter net

5. Reinstall filter and angle valve nut, turn on the angle valve and connect power, then it can work normally after self inspection.

### No water supply

- Put around 8L water into a barrel and flush the bowl of ceramic.

Note: Avoid water spilling from bowl.

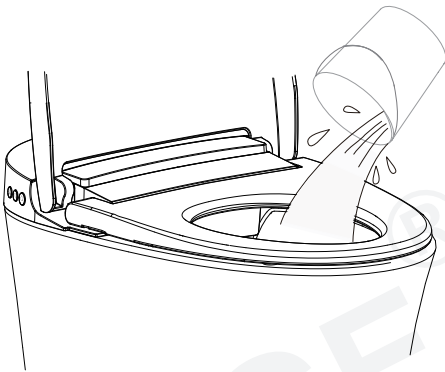

### Replacement of battery

- Unplug the DC plug on of the battery box and remove the battery box from the bottom of the toilet.
- Remove the battery box cover and replace old batteries with new batteries, re-install the cover.
- Insert the battery box's DC plug into the DC socket of toilet and stick the battery box to the Velcro on the bottom of the toilet.

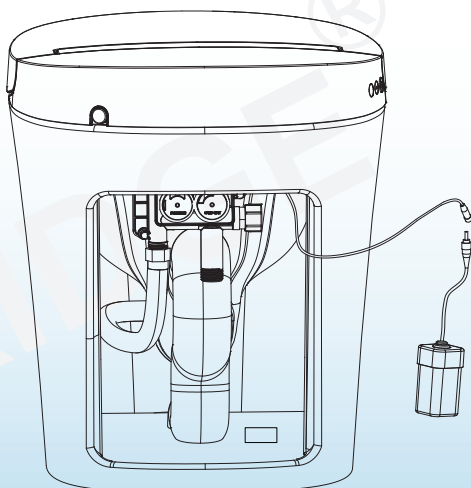

### Low voltage battery determination and replacement

(Only apply to models with wave-to-flush function)

#### 1. Sensor module is low voltage

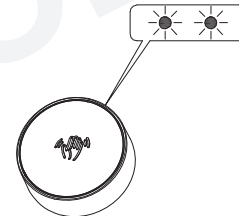

- During the use of the product, wave to sense, the indicator light of the sensor module quick flashes 5 times, indicating that the battery is low voltage and needs to be replaced.



- Unscrew the screws on the back cover and remove back cover from the sensor module, replace batteries and tighten the screws again.

Note:

1. Battery must be 1.5 V "AAA" size alkaline battery.
2. Different brands, different used and new batteries can not be mixed.
3. Battery life will be significantly reduced when using non-alkaline batteries.

## 2.Low battery

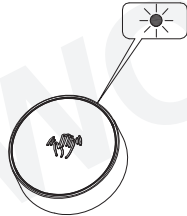

- During the use of the product, wave to sense, the indicator light of the sensor module slow flashes 12 times, indicating that the battery is at low voltage and needs to be replaced.

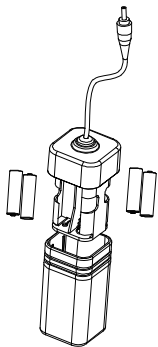

Step I

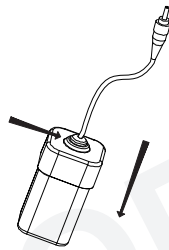

Step II

- Unscrew the screws on the back cover and remove back cover from the control module, replace batteries and tighten the screws again. Pay attention to inner box direction when installing.

### Notes:

1. Must be 1.5V "AA" alkaline battery;
2. Different brands, different used and new batteries cannot be mixed.
3. Battery life will be significantly reduced when using non-alkaline batteries;
4. When installing the inner box components, follow the installation direction shown in the label.

## When the product is left unused for long time

- Especially in winter when no one at home for a long time, please drain out the water inside tank and pipe to prevent freezing.

### To discharge water

1. Drain out the water inside tank
  - Activate flushing, and then turn off angle valve to prevent water inlet.
2. Unplug and remove the battery box and then remove all batteries.
3. Drain out the water inside pipe
  - Unscrew the hose connector off angle valve, drain the water in the pipe and reinstall.

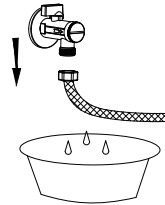

4. Handle the remaining water in bowl

- It is suggested to put some antifreeze into water inside the bowl.

Tips: When using the toilet again, re-connect the water supply and re-install the battery box.





Note: Before water discharging, the power must be cut off!



Model		BW5100S
<b>Main Unit</b>	Overall unit Waterproof	IPX4
<b>Toilet</b>	Flush volume	Full flush 6.0L/Half flush 4.2L
	Flushing mode	Siphonic jet
	Rough-in distance	12"
	Outlet outside diameter	3 1/2"
	Drainage method	Down-drain
	Water pressure range	0.09MPa (dynamic water pressure, flow rate 15.0 L/min or more)--0.8MPa (static water pressure)
	Installation method	Silicone sealant/foundation bolts
<b>seat</b>	Open and close device	Quiet soft-closing device
<b>Caring device</b>	Automatic flushing	Toilet will automatically flush as user walks away from bowl
	Low battery indication	If the battery is low, when pressing the flush button, the indicator light will flash, indicating batteries need to be replaced.
	Foot-touch flushing function	Kick the foot-touch button to flush (optional)
	Wave-to-flush function	Wave in front of sensor module to flush (optional)
Antibacterial position		Seat

## The illustration of Main Unit Keys

The illustration of main unit buttons		
	 Flush	short press the "flushing" button on the main unit to turn on the flush function. (FULL FLUSH)

**Notes:**

1. Button light: If the battery is low, when pressing the flush button, the red light will flash.
2. Off-seat auto flushing: In the off-seat auto flushing mode, if a user is seated for ≥6s and ≤1 min, and leaves the seat for >3s, the toilet will activate a half flush. If a user is seated for >1 min, and leaves the seat for >3s, the toilet will activate a full flush.

Model No.		Customer Name	
Seller:		Date of Purchased:	
Invoice No.		Customer contact:	
Distributor		Distributor Phone	

Thank you for choosing our product. This product is warranted for One(1) years since the purchasing date for free repair of problems arising out of defects in workmanship while using in accordance with installation manual and usage cautions for intended purposes.

If the product does not work properly with warranty period, please contact your nearest service center. This certificate must be presented to obtain free service under this warranty.

Our company reserves the rights to replace the product by other similar models.

We can serve to fix or repair the product at a reasonable service charge, after expiration of warranty period.

Service charges shall be paid even during the warranty period, if breakage or damage is caused by any of the following events (including but without limitation).

1. The user's negligence or mistake in operation, unreasonable repair or alteration.
2. Product are damaged by negligence or mistake during installation.
3. The movement of installation location of the product.
4. Using the product outside of intended use in residential housing or commercial hotels.
5. The use of non specified power supply (voltage, rating pressure)
6. The dirt, sand and impurities that causing invalid operation.
7. Damages due to force majeure (including but not limitation to natural disaster) or other incidents.
8. The user fails to use in compliance with the warning or caution described in the installation manual.

Remark.

Please fill in date, seller correctly. If there are some mistakes, the warranty will get invalid.

This three year warranty for free of charge of repair service is only for the items listed in the warranty.

The purchasing date is subject to the purchasing invoice or receipt.

Please keep this warranty and invoice/receipt available for repair or maintenance.



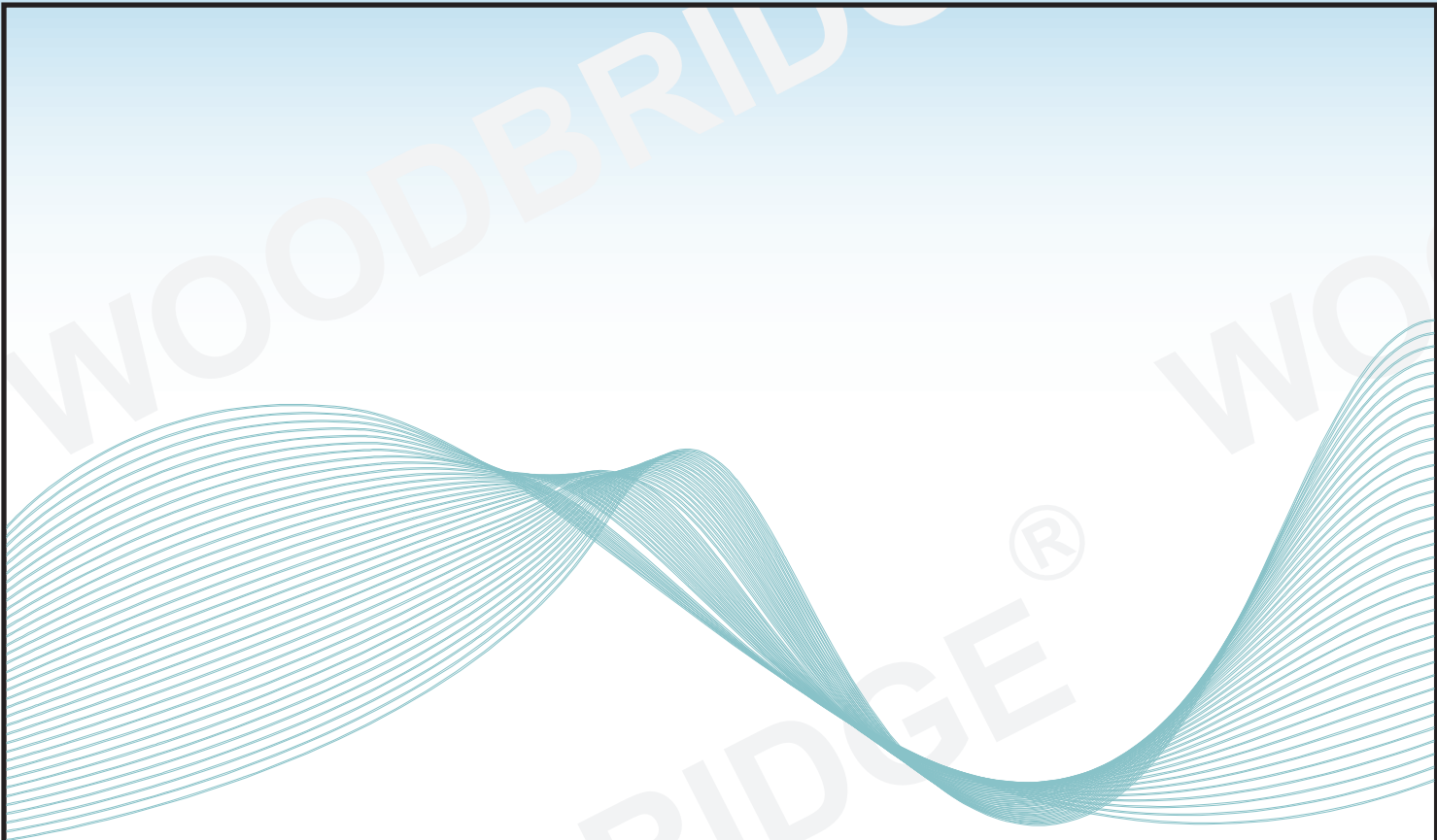

SCAN ME

Thank you for using WoodBridge products!

Customer Service Phone: 562-229-0088. (Monday - Friday 9 AM - 5 PM Pacific Time)

Or Email: [help@woodbridgebath.com](mailto:help@woodbridgebath.com)

[www.woodbridgebath.com](http://www.woodbridgebath.com)